

Harvatek High Power LED Approval Sheet
Model No.: HT-R178BPV-406

Official Product	HT Part No. HT-R178BPV-406	Your Part No.		Data Sheet No.
Tentative Product	*****	*****		
Specifications are subject to changes for improvement without advance notice. Proprietary data, drawings, and company confidential all rights reserved.		2007/12/17	Version of 1.2	Page 1/15

INTRODUCTION	3
PRODUCT SPECIFICATION	4
ATTENTION: ELECTRIC STATIC DISCHARGE (ESD) PROTECTION	4
LABEL SPECIFICATIONS	5
DESCRIPTION OF MODEL NO. AND LOT NO.	5
MODEL NO.....	5
LOT No.....	5
PRODUCT FEATURE.....	6
APPLICATION.....	6
PRODUCT OUT LINE DIMENSION (HT-R178BPV).....	6
ELECTRO-OPTICAL	6
ABSOLUTE MAXIMUM RATINGS	6
ELECTRO-OPTICAL CHARACTERISTICS	7
LUMINOUS FLUX RANK	7
ELECTRICAL RANK.....	7
CORRELATED COLOR TEMPERATURE RANK.....	8
COLOR TEMPERATURE CORRDNATES.....	9
CHARACTERISTICS	10
LEDs AND EYE SAFETY:.....	11
PACKING	12
TAPE DIMENSION.....	12
REEL DIMENSION	13
PACKING	13
PRECAUTION OF APPLICATION	14
DESIGNING 1: SOLDERING PATTERN	14
DESIGNING 2: CIRCUIT LAYOUT.....	14
DESIGNING 3: MAX RATING.....	14
STORAGE	14
SOLDERING	15
CLEANING.....	15
REVISE NOTES	15

Official Product	HT Part No. HT-R178BPV-406	Your Part No.		Data Sheet No.
Tentative Product	*****	*****		
Specifications are subject to changes for improvement without advance notice. Proprietary data, drawings, and company confidential all rights reserved.		2007/12/17	Version of 1.2	Page 2/15

Introduction

- The information contained herein is presented only as a guide for the applications of our products. No responsibility is assumed by HARVATEK for any infringements of intellectual property or other rights of the third parties which may result from it use.
- HARVATEK is continually making an effort to improve the quality of its products. Nevertheless, semiconductor devices in general can malfunction or fail due to their inherent electrical sensitivity and vulnerability to physical stress. It is the responsibility of the buyer, when utilizing HARVATEK products, to comply with the standards of safety in making a safe design for the entire system, and to avoid situations in which a malfunction or failure of such HARVATEK products cause loss of human life, bodily injury or damage to property.
- The HARVATEK products listed in this document are intended for usage in general electronics (computer, personal equipment, office equipment, industrial robotics, domestic, etc...) These products are neither intended nor warranted for usage in equipment that requires extraordinarily high quality and/or reliability or a malfunction or failure of which may cause loss of human life or bodily injury.
- In developing your designs, please ensure that HARVATEK products are used within specified operating ranges as set forth in the most recent HARVATEK products specifications.
- Also, please keep in mind of the precautions listed in this document.







Official Product	HT Part No. HT-R178BPV-406	Your Part No.		Data Sheet No.
Tentative Product	*****	*****		
Specifications are subject to changes for improvement without advance notice. Proprietary data, drawings, and company confidential all rights reserved.		2007/12/17	Version of 1.2	Page 3/15

Product Specification

	Specification	Material	Quantity
Total Flux	Typical 140 lm @ 700mA/ Ta= 25°C		
Correlated Color Temperature	3000K~9000K @ 700mA/ Ta=25°C		
V _F	3.03-3.99V @ 700mA/ Ta=25°C		
I _R	HT standard		
Resin	White	Silicon Resin	
Carrier tape	EIA 481-1A specs	Conductive black tape	250pcs per reel
Reel	EIA 481-1A specs	Anti-Static Blue	
Label	HT standard	Paper	
Carton	HT standard	Paper	Non-specified
Others:			
<p>ATTENTION: Electric Static Discharge (ESD) protection</p>  <p>The symbol shown on the page herein to introduce 'Electro-Optical Characteristics'. ESD protection for GaP and AlGaAs based chips is still necessary even though they are safe in low static-electric discharge. Parts built with AlInGaP, GaN, or/and InGaN based chips are STATIC SENSITIVE devices. ESD protection has to considered and taken in the initial design stage. If manual work/process is needed, please ensure the device is well protected from ESD during all the process.</p>			

Official Product	HT Part No. HT-R178BPV-406	Your Part No.		Data Sheet No.
Tentative Product	*****	*****		
Specifications are subject to changes for improvement without advance notice. Proprietary data, drawings, and company confidential all rights reserved.		2007/12/17	Version of 1.2	Page 4/15

Label Specifications

HARVATEK		DATE: dd/mm/yyyy		
CUSTOMER P/N:				
HARVATEK P/N:		QTY:	PCS	
LOT NO:		QC:		
IV BIN:		VF:		
	COLOR BIN:			

Description of Model No. and Lot No.

Model No.

H T - R 1 7 8 B P V-406

Company	Product Name	Dice	Package	Emitter Color	Current code
HT: For Harvatek	R: Power Package (Reversed polarity) With Zener Diode	1: Single 2: Twin	Outline dimension	BP: White	V:700Ma 406: product code

Lot No.

1 2 3 4 5 6 7 8 9 10
P 1 2 2 3 0 A - C T

Code 1	Code 2	Code 3	Code 4, 5	Code 6, 7	Code 9	Code 10
	Mfg. Year	Mfg. Month	Mfg. Date	Lots	Resin Color	Packaging
Internal Tracing Code	Z: 2000 1: 2001	1: Jan. 2: Feb. 9: Sep. A: Oct. B: Nov. C: Dec.	1~31/ (30)	01~99, A,B,C...	D: Water clear	T: Tape

Official Product	HT Part No. HT-R178BPV-406	Your Part No.	Data Sheet No.
Tentative Product	*****	*****	
Specifications are subject to changes for improvement without advance notice. Proprietary data, drawings, and company confidential all rights reserved.		2007/12/17	Version of 1.2 Page 5/15

Product Feature

- Wide view angle
- Easy to fixed
- No UV
- Long operating time (Up to 50,000hrs)
- Lower forward voltage operated
- More energy efficient than incandescent and most halogen lamps
- ESD with 8KV
- Instant light (less than 100nS)

Application

- Reading lights (car, bus, aircraft)
- Portable (flashlight, bicycle)
- Task lighting
- Garden lighting
- Rail lighting
- Wayside lighting
- LCD Backlights
- Light Guides
- Traffic signaling
- Architectural lighting

Product Out Line Dimension (HT-R178BPV)

Tolerance: +/-0.1

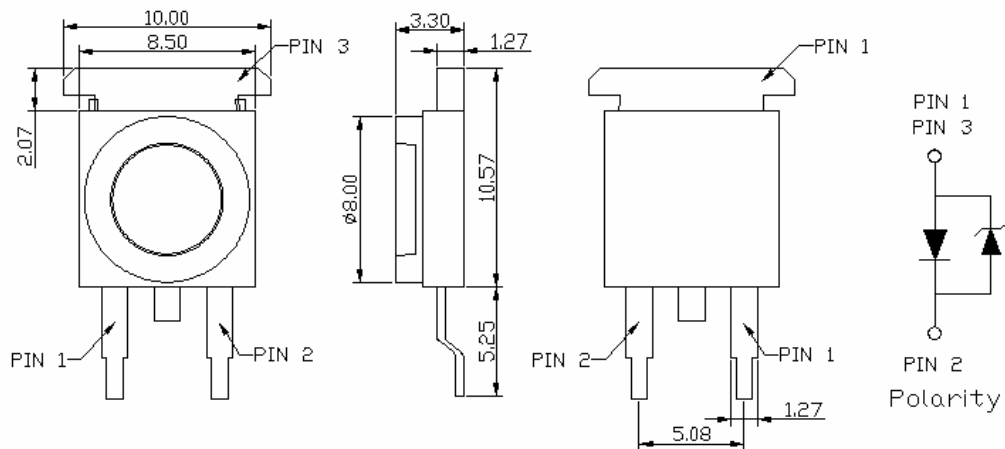

Electro-Optical

Absolute Maximum Ratings

(Ta = 25°C)

Parameter	Rating	Unit	Conditions
DC Forward Current ^{*1}	800	mA	-
Peak Pulsed Forward Current ^{*2}	1000	mA	-
Reverse Voltage	5	V	-
LED junction Temperature	120	°C	-
Operating Temperature	-30~+85	°C	-
Storage Temperature	-40~+120	°C	-
Soldering Temperature	260	°C	For 5 sec. Max.

Official Product	HT Part No. HT-R178BPV-406	Your Part No.	Data Sheet No.
Tentative Product	*****	*****	
Specifications are subject to changes for improvement without advance notice. Proprietary data, drawings, and company confidential all rights reserved.		2007/12/17	Version of 1.2 Page 6/15

*1: Proper current derating must be observed to maintain junction temperature below the maximum

*2: $t_p \leq 10\mu s$, Duty cycle=0.01

Electro-Optical Characteristics

($T_a = 25^\circ C$)

Parameter	Symbol	Min.	TYP.	Max.	Unit
Viewing angle	$2\theta \frac{1}{2}$	-	110	-	Deg.
Forward Voltage ($I_F=700mA$)	V_F	3.03	-	3.99	V
Luminous Flux	Flux	113.6	147	-	lm
Correlated Color Temperature	CCT	3000	-	9000	K
Temperature Coefficient of Forward Voltage	$\Delta V_F/\Delta T$	-	-2	-	mV/ $^\circ C$
Thermal Resistance Junction to Board ($I_F=700mA$)	$R\theta_{J-B}$	-	8	-	$^\circ C/W$

Luminous Flux Rank

Rank Code	Symbol	Condition	Min.	Typ.	Max.	Unit
Full	ΦV	$I_F=700mA$	87.4	-	192.0	lm
PU1			87.4	-	99.6	
PU2			99.6	-	113.6	
PV1			113.6	-	129.5	
PV2			129.5	-	147.7	
PW1			147.7	-	168.4	
PW2			168.4	-	192.0	

Note: It maintains a tolerance of $\pm 10\%$ on flux

Electrical Rank

Rank Code	Symbol	Condition	Min.	Typ.	Max.	Unit
Full	V_F	$I_F=700mA$	3.03	-	3.99	V
P05			3.03	-	3.27	
P06			3.27	-	3.51	
P07			3.51	-	3.75	
P08			3.75	-	3.99	

Note: It maintains a tolerance of $\pm 0.1V$ on forward voltage measurements

Official Product	HT Part No. HT-R178BPV-406	Your Part No.		Data Sheet No.
Tentative Product	*****	*****		
Specifications are subject to changes for improvement without advance notice. Proprietary data, drawings, and company confidential all rights reserved.		2007/12/17	Version of 1.2	Page 7/15

Correlated Color Temperature Rank

Color	Condition	Bin Code	Min.	Typ.	Max.	Unit
Warm White	$I_F=700\text{mA}$	L1	2,750	3,000	3,250	K
		L0	2,750	3,000	3,250	
		K1	3,250	3,500	3,750	
		K0	3,250	3,500	3,750	
		J1	3,750	4,000	4,250	
		J0	3,750	4,000	4,250	
		H12	4,250	4,375	4,500	
		H02	4,250	4,375	4,500	
		H11	4,500	4,625	4,750	
		H01	4,500	4,625	4,750	
Pure White		G02	4,750	4,875	5,000	
		G12	4,750	4,875	5,000	
		G11	5,000	5,125	5,250	
		G01	5,000	5,125	5,250	
		F12	5,250	5,375	5,500	
		F02	5,250	5,375	5,550	
		F11	5,500	5,625	5,750	
		F01	5,550	5,625	5,750	
		E12	5,750	5,875	6000	
		E02	5,750	5,875	6,000	
		E11	6,000	6,125	6,250	
		E01	6,000	6,125	6,250	
		D12	6,250	6,375	6,500	
		D02	6,250	6,375	6,500	
Cold White		D11	6,500	6,625	6,750	
		D01	6,500	6,625	6,750	
		C1	6,750	7,000	7,500	
		C0	6,750	7,000	7,500	
		B1	7,500	8,000	8,500	
B0		7,500	8,000	8,500		
A	8,500	9,000	9,500			

Note: It maintains a tolerance of $\pm 5\%$ on CCT

Official Product	HT Part No. HT-R178BPV-406	Your Part No.		Data Sheet No.
Tentative Product	*****	*****		
Specifications are subject to changes for improvement without advance notice. Proprietary data, drawings, and company confidential all rights reserved.		2007/12/17	Version of 1.2	Page 8/15

Color Temperature Corrdinates

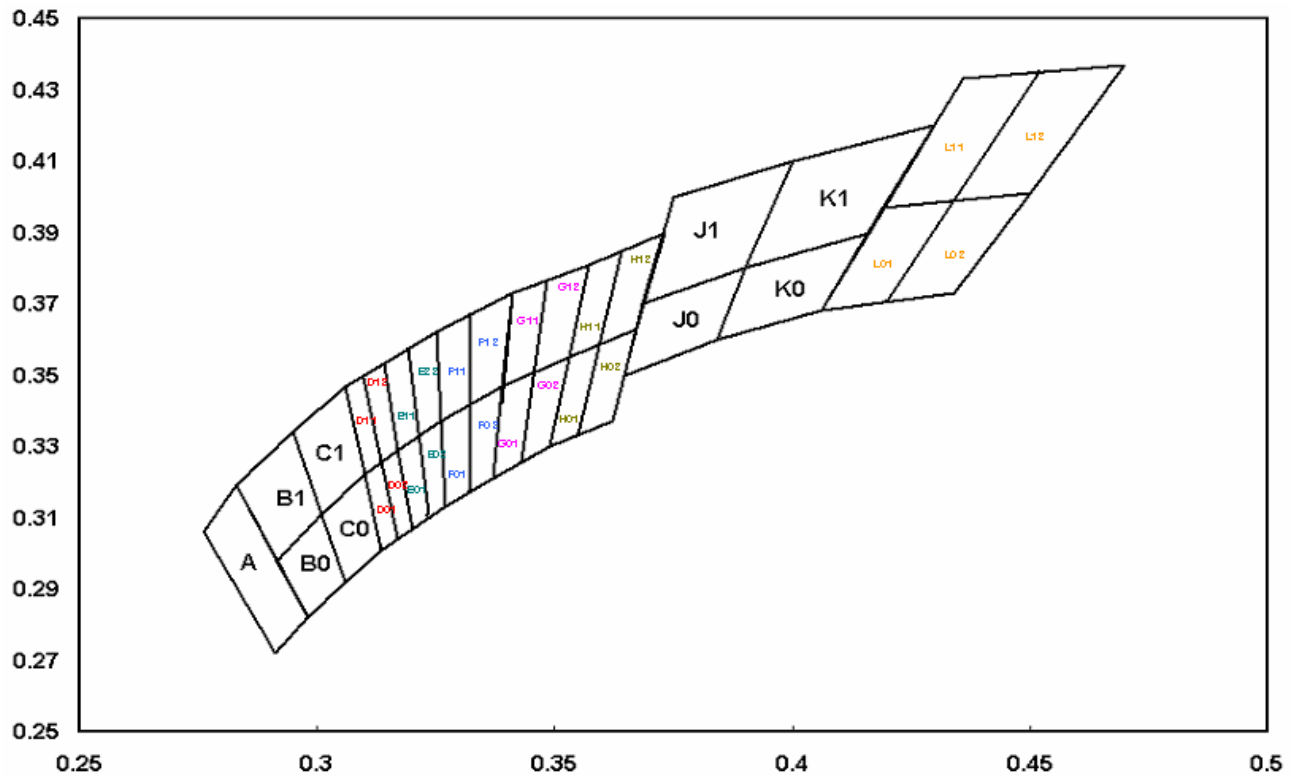

Official Product	HT Part No. HT-R178BPV-406	Your Part No.		Data Sheet No.
Tentative Product	*****	*****		
Specifications are subject to changes for improvement without advance notice. Proprietary data, drawings, and company confidential all rights reserved.		2007/12/17	Version of 1.2	Page 9/15

Characteristics

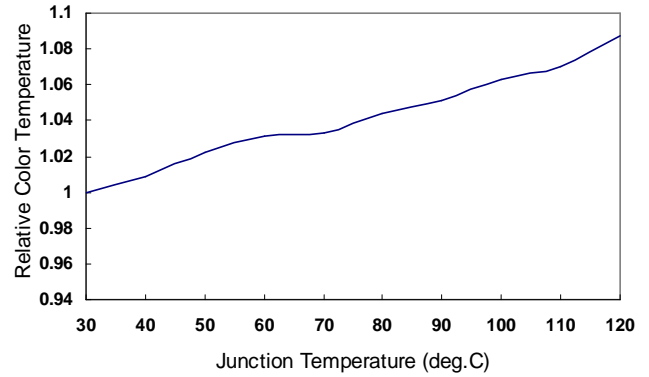
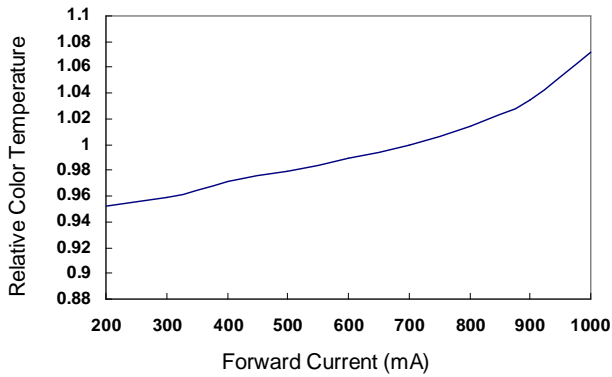
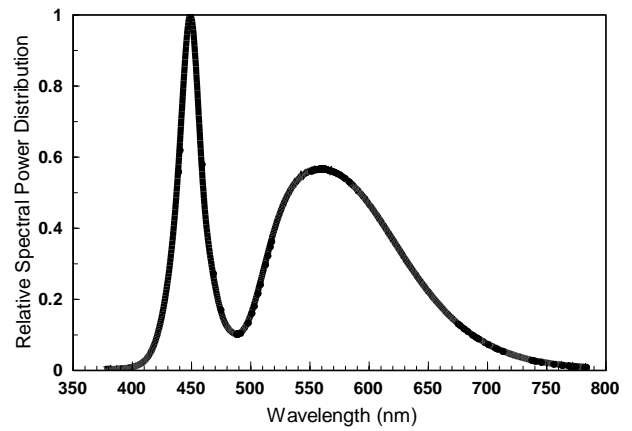
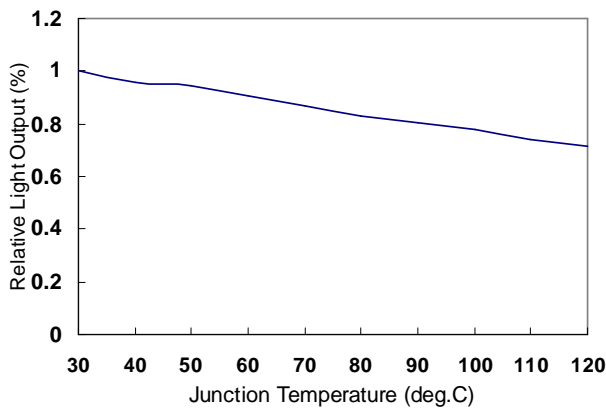
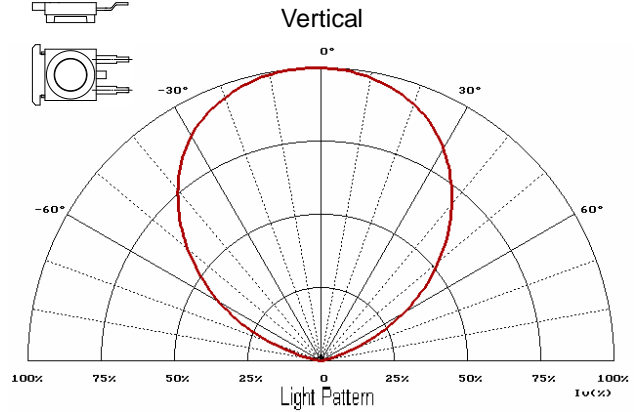
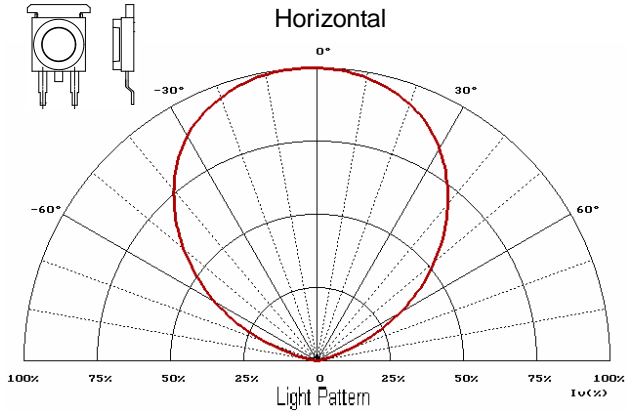

Official Product	HT Part No. HT-R178BPV-406	Your Part No.	Data Sheet No.
Tentative Product	*****	*****	
Specifications are subject to changes for improvement without advance notice. Proprietary data, drawings, and company confidential all rights reserved.		2007/12/17	Version of 1.2
			Page 10/15

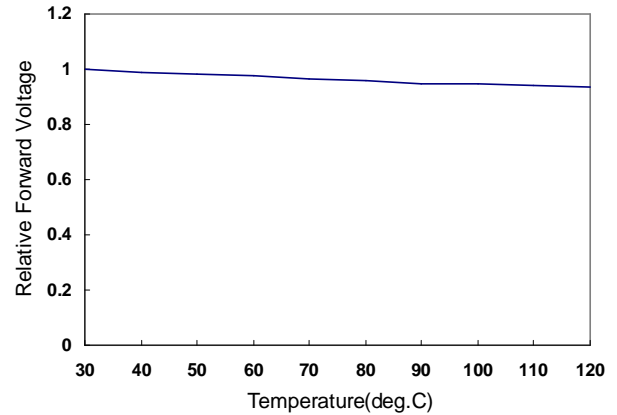
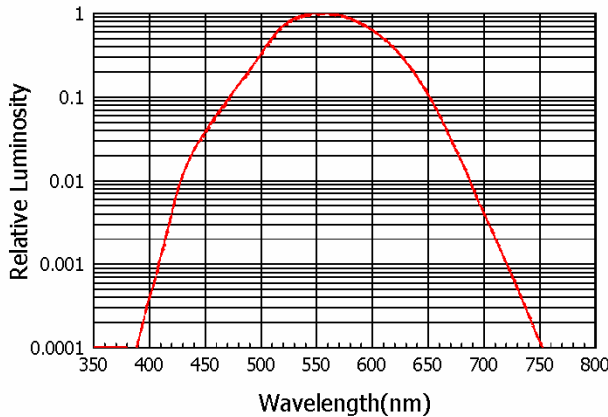
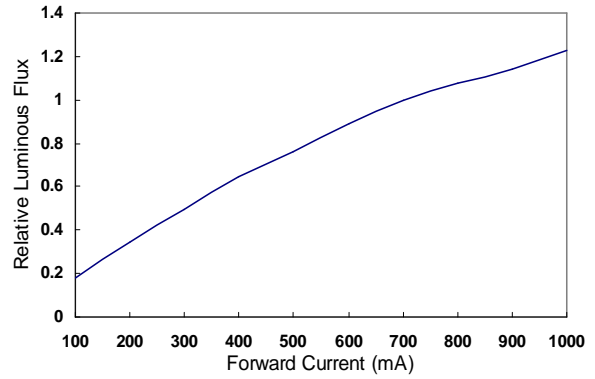
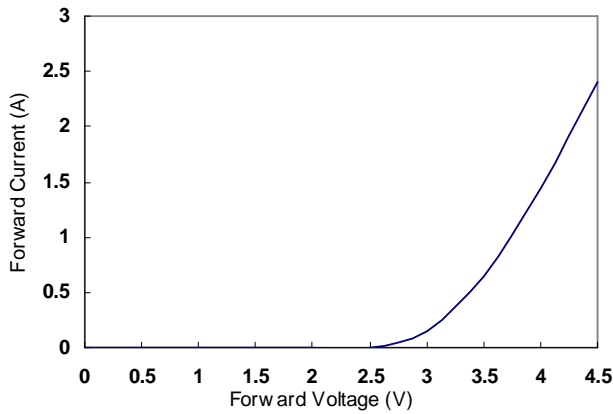

LEDs and Eye Safety:

In the 1993 edition of IEC-60825-1, LEDs were included: "Throughout this part 1 light emitting diodes (LED) are included whenever the word "laser" is used."The CENELEC document EN 60825-1 contains all the technical content of the IEC standard.

The scope of the IEC standard states that "...products which are sold to other manufacturers for use as components of any system for subsequent sale are not subject to IEC 60825-1, since the final product will itself be subject to this standard. "Therefore, it is important to determine the Laser Safety Class of the final product. However, it is important that employees working with LEDs are trained to use them safely.

Most of the products containing LEDs will fall in either Class 1 or Class 2. A Class 1 label is optional:

CLASS 1 LED PRODUCT

If a label is not used, this description must be included in the information for the user.

Amendment 2 to IEC 60825-1 is expected to be published in January 2001. The CENELEC equivalent is expected to follow three months after the IEC publication. This document contains increased Class 1 and Class 2 limits, as well as the introduction of less restrictive Class 1M and Class 2M.

For the exact classification and further information, the IEC document can be used:

IEC-60825-1 ISBN 2-8318-4169-0

Official Product	HT Part No. HT-R178BPV-406	Your Part No.	Data Sheet No.
Tentative Product	*****	*****	
Specifications are subject to changes for improvement without advance notice. Proprietary data, drawings, and company confidential all rights reserved.		2007/12/17	Version of 1.2
			Page 11/15

Packing Tape Dimension

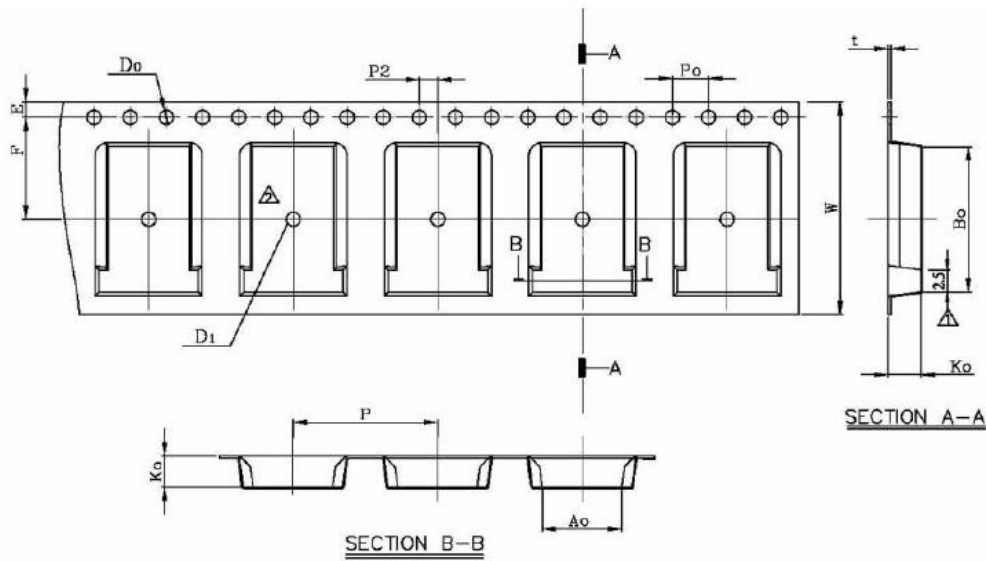

Part No.	Dim. A0	Dim. B0	Dim. K0	Dim. W	Dim. P	Q'ty/Reel
HT-R178	8.80±0.10	16.45±0.10	3.60±0.10	24.0±0.10	16.0±0.10	250EA

Unit: mm

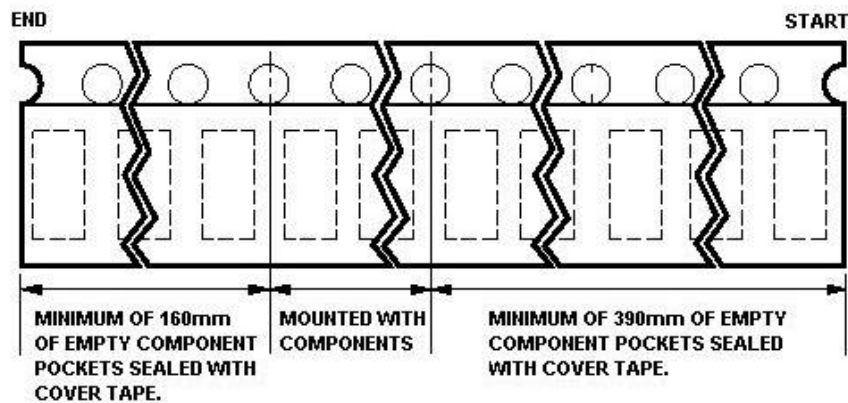

Official Product	HT Part No. HT-R178BPV-406	Your Part No.	Data Sheet No.
Tentative Product	*****	*****	
Specifications are subject to changes for improvement without advance notice. Proprietary data, drawings, and company confidential all rights reserved.		2007/12/17	Version of 1.2
			Page 12/15

Reel Dimension

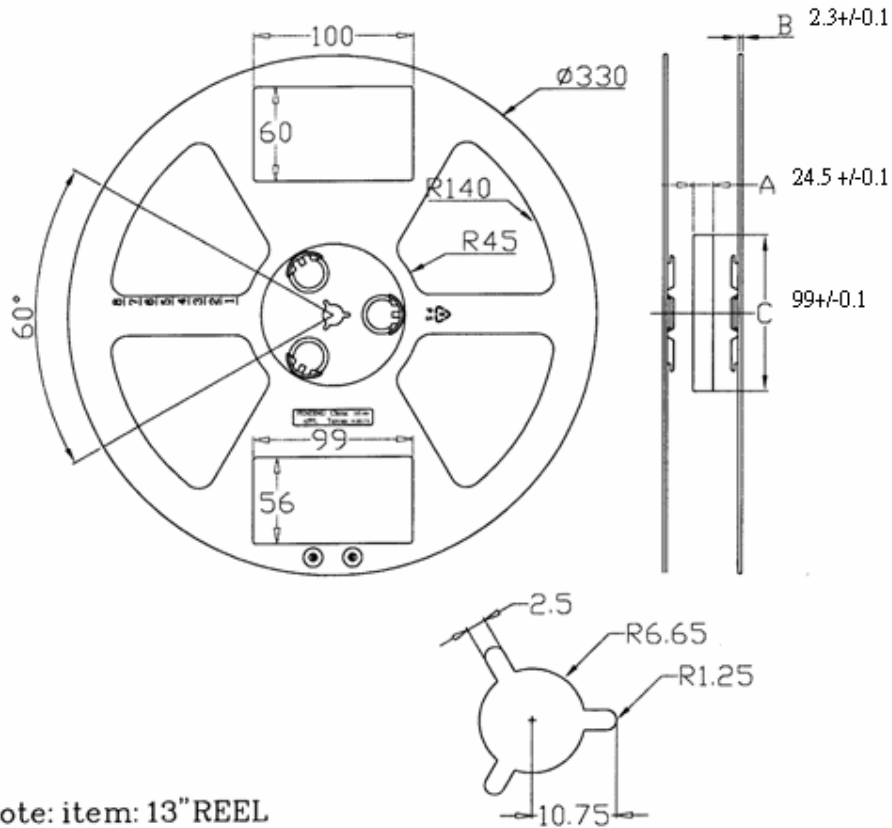

note: item: 13" REEL
ANTI-STATIC $\leq 10^{10} \Omega/\square$
material: P.S

Packing

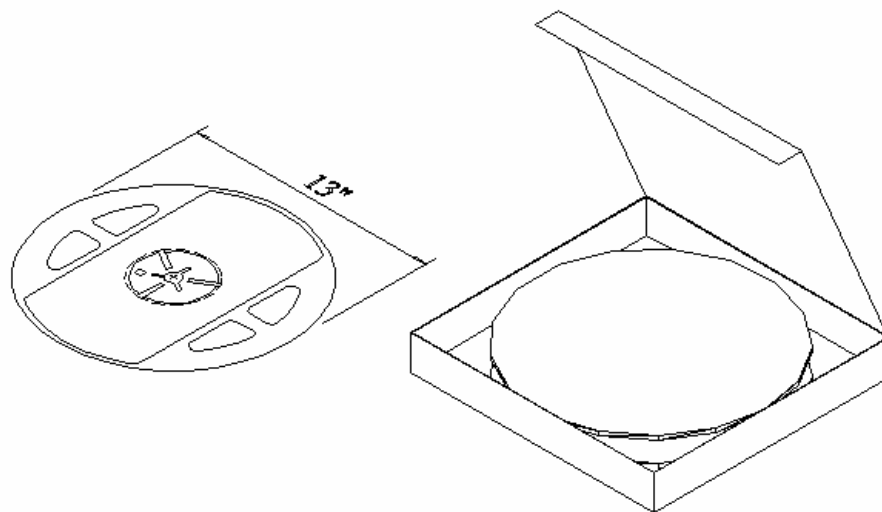

Official Product	HT Part No. HT-R178BPV-406	Your Part No.		Data Sheet No.
Tentative Product	*****	*****		
Specifications are subject to changes for improvement without advance notice. Proprietary data, drawings, and company confidential all rights reserved.		2007/12/17	Version of 1.2	Page 13/15

Precaution of Application

Designing 1: Soldering Pattern

The dimensions of the recommended soldering pattern may not meet every user. Please confirm and study first before designing the soldering pattern in order to obtain the best performance of soldering. Recommended soldering pattern is listed below:

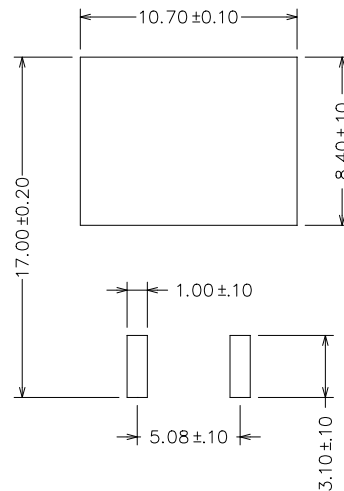

Designing 2: Circuit Layout

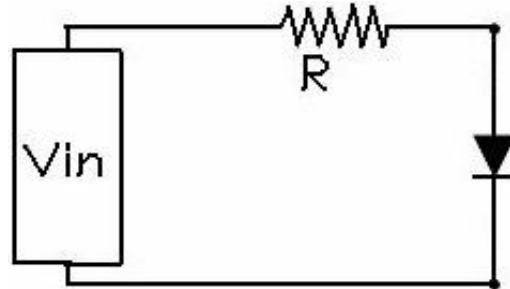

Designing 3: Max Rating

Any application should refer to the specifications of absolute maximum ratings.

Storage

It's recommended to store the products in the following conditions:

Humidity: 60 %RH Max.

Temperature: 5°C ~30°C (41°F~86°F)

Official Product	HT Part No. HT-R178BPV-406	Your Part No.		Data Sheet No.
Tentative Product	*****	*****		
Specifications are subject to changes for improvement without advance notice. Proprietary data, drawings, and company confidential all rights reserved.		2007/12/17	Version of 1.2	Page 14/15

Soldering

Manual soldering

Soldering tin material: tin 6/4 alloy or contained Ag.

To prevent cracking, please bake before manual soldering.

Temperature at tip of iron : 300°C±5°C Max.(25W)

It's banned to load any stress on the resin during soldering.

Soldering time : 3±1sec

Cleaning

The conditions of cleaning after soldering:

An alcohol-based solvent such as isopropyl alcohol (IPA) is recommended.

Temperature Time: <50°C×30sec, or <30°C×3min

Ultra sonic cleaning: < 15W/ bath; Bath volume: 1liter max.

Curing: 100°C max, <3min

Revise Notes

Rev.	Descriptions	Date
1.0	-	2006/2/23
1.1	Change packing from Tube to Reel	2007/4/3
1.2	Added product code	2007/12/17

Official Product	HT Part No. HT-R178BPV-406	Your Part No.		Data Sheet No.
Tentative Product	*****	*****		
Specifications are subject to changes for improvement without advance notice. Proprietary data, drawings, and company confidential all rights reserved.		2007/12/17	Version of 1.2	Page 15/15