

Features

- Collimate the light source
- 30° viewing angle
- Optical grade plastic

Typical Application

- CCD lighting
- Night vision light source
- Other aids lighting

■ Mechanical Outline Dimensions

General Tolerance: +/-0.1

Outline Dimension :

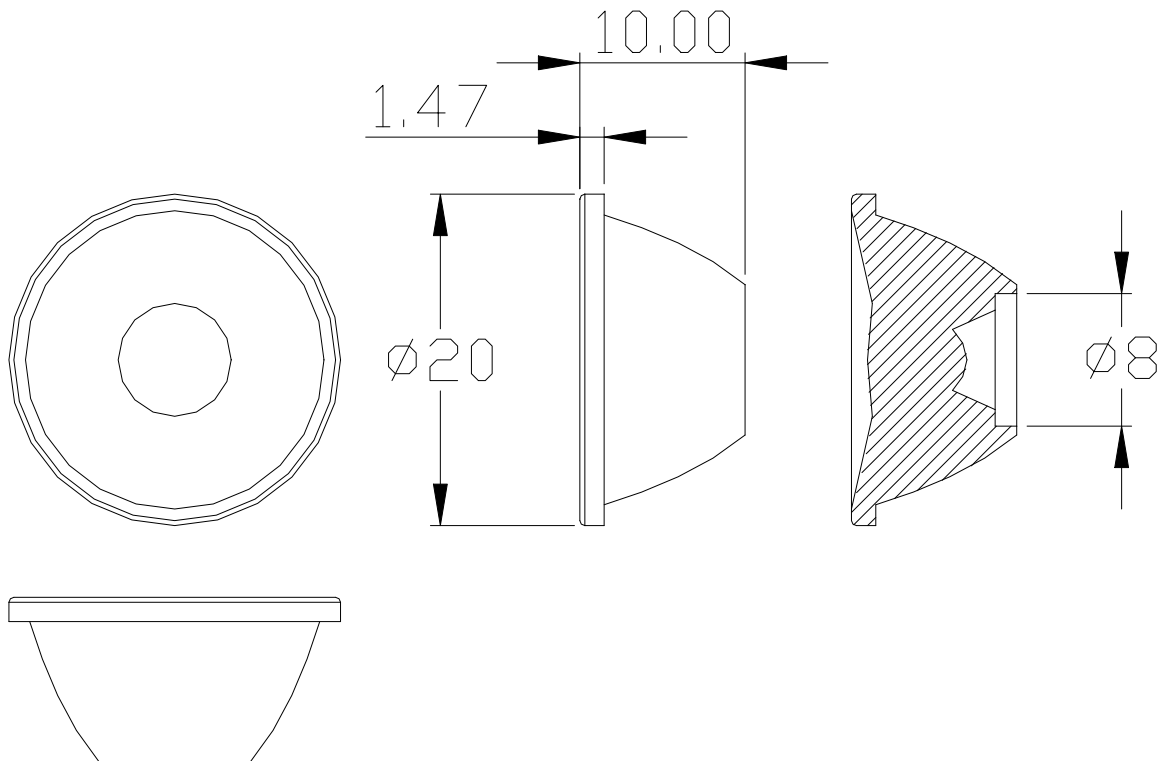

Unit: mm

Specifications are subject to changes for improvement without advance notice.

Caution: This product specification is a TENTATIVE EDITION. Its mechanical dimension, layout and electro-optical properties may be revised to improve product quality and reliability.

07-19-2005

Version of 1.0

Page 1/2

■ Radiation Pattern

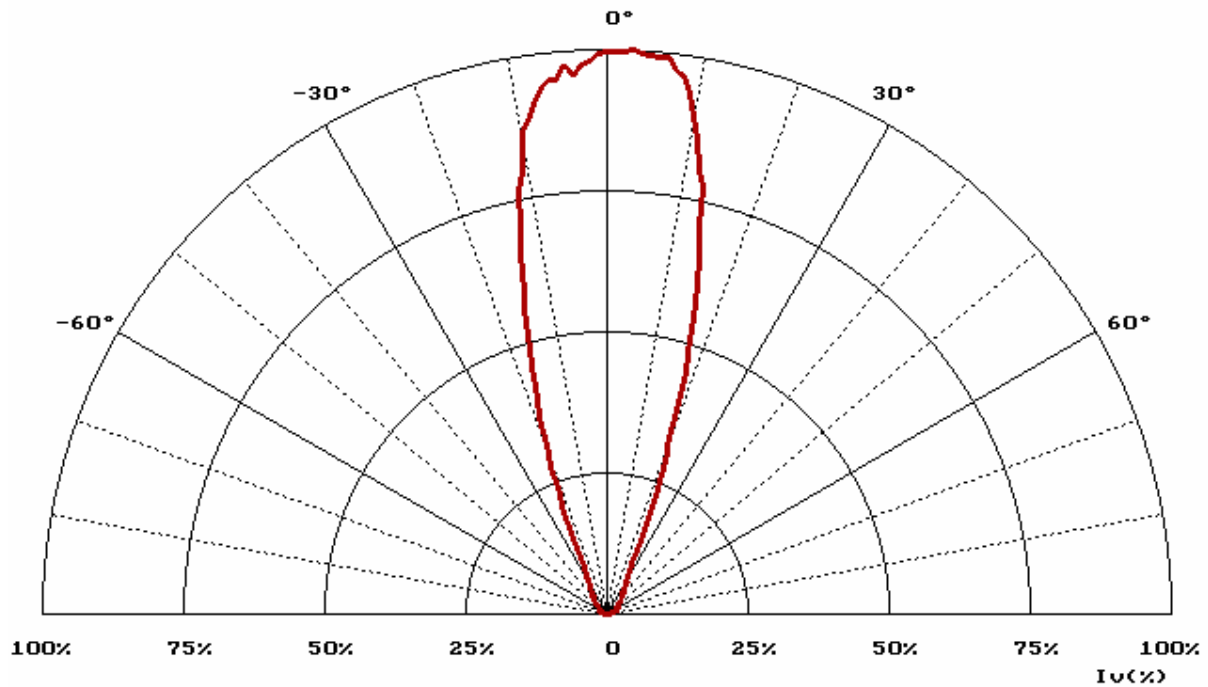
**HARVATEK**<http://www.harvatek.com.tw><mailto:sales@harvatek.com.tw>

No 18 Lane 522 Sec 5 Chung Hwa Rd Hsin Chu Taiwan, R.O.C.

Tel : +886-3-539-9889

Fax : +886-3-539-9227

Specifications are subject to changes for improvement without advance notice.

Caution: This product specification is a **TENTATIVE EDITION**. Its mechanical dimension, layout and electro-optical properties may be revised to improve product quality and reliability.

07-19-2005

Version of 1.0

Page 2/2