

**Harvatek Surface Mount CHIP LEDs Approval Sheet
Model No.: HT-193BP5**

Acknowledged by

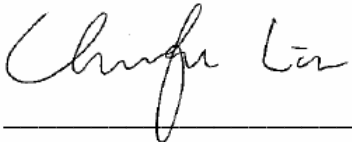

**Section Manager
Production Engineering Dept.**

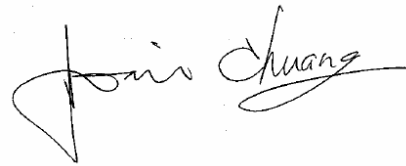

**Manager
Production Engineering Dept.**

Official Product	HT Part No. HT-193BP5	Your Part No.		Data Sheet No.
Tentative Product	*****	*****		HDS-193-K425
Specifications are subject to changes for improvement without advance notice. Proprietary data, drawings, and company confidential all rights reserved.		2006/12/5	Version of 2.0	Page 1/13

INTRODUCTION.....	2
PRODUCT SPECIFICATION	3
ATTENTION: ELECTRICSTATIC DISCHARGE (ESD) PROTECTION	4
LABEL SPEC.:.....	5
PRODUCT FEATURE.....	7
ELECTRO-OPTICAL CHARACTERISTICS.....	7
PACKAGE OUTLINE DIMENSION AND RECOMMENDED SOLDERING PATTERN FOR REFLOW	
SOLDERING	7
ABSOLUTE MAXIMUM RATINGS	7
CHARACTERISTICS OF HT-193 SERIES.....	8
PACKAGING TAPE, REEL, AND PACKING MODEL.....	9
TAPE DIMENSION	9
REEL DIMENSION.....	9
PACKING MODEL	10
DRY PACK.....	10
CAUTIONS OF PICK AND PLACE.....	11
PRECAUTIONS.....	11
REFLOW SOLDERING	11
LEAD SOLDER	12
REWORK.....	12
RELIABILITY TEST	13

Introduction

- *The information contained herein is presented only as a guide for the applications of our products.*

Official Product	HT Part No. HT-193BP5	Your Part No.		Data Sheet No.
Tentative Product	*****	*****		HDS-193-K425
Specifications are subject to changes for improvement without advance notice. Proprietary data, drawings, and company confidential all rights reserved.		2006/12/5	Version of 2.0	Page 2/13

No responsibility is assumed by HARVATEK for any infringements of intellectual property or other rights of the third parties which may result from it use.

- *Harvatek is continually effort to improve the quality of its products. Nevertheless, semiconductor devices in general can malfunction or fail due to their inherent electrical sensitivity and vulnerability to physical stress. It is the responsibility of the buyer, when utilizing HARVATEK products, to comply with the standards of safety in making a safe design for the entire system, and to avoid situations in which a malfunction or failure of such HARVATEK products cause loss of human life, bodily injury or damage to property.*
- *The HARVATEK products listed in this document are intended for usage in general electronics (computer, personal equipment, office equipment, industrial robotics, domestic, etc...) These products are neither intended nor warranted for usage in equipment that requires extraordinarily high quality and/or reliability or a malfunction or failure of which may cause loss of human life or bodily injury.*
- *In developing your designs, please ensure that HARVATEK products are used within specified operating ranges as set forth in the most recent HARVATEK products specifications.*
- *Also, please keep in mind the precautions listed in this document.*

Product Specification

	Specification	Material	Quantity
--	---------------	----------	----------

Official Product	HT Part No. HT-193BP5	Your Part No.		Data Sheet No.
Tentative Product	*****	*****		HDS-193-K425
Specifications are subject to changes for improvement without advance notice. Proprietary data, drawings, and company confidential all rights reserved.		2006/12/5	Version of 2.0	Page 3/13

Iv	45-180mcdmcd @5mA/ Ta= 25° C Tolerance: ± 10%		
Chromaticity Coordinates	Refer to page 6 @5mA/ Ta= 25° C Tolerance: ± 0.5nm		
Vf	2.55-3.15V @5mA/ Ta= 25° C Tolerance: ± 0.05V		
Ir	< 100 µA @ V _R = 5 V		
Resin	Milky White	Epoxy resin	
Carrier tape	According to EIA 481-1A specs	Conductive black tape	4000pcs per reel
Reel	According to EIA 481-1A specs	Conductive black	
Label	HT standard	Paper	
Packing bag	220x240mm	Aluminum laminated bag/ no-zipper	One reel one bag
Carton	HT standard	Paper	Non-specified

Others:

Every mid-box will be loaded 5 reels. These 5 reels can be different in lot, Iv, lambda, or Vf. Every reel will have an independent label to identify its specification and the mid-box there will have a corresponding label post on it.

ATTENTION: Electricstatic Discharge (ESD) protection



The symbol shown on the page herein to introduce 'Electro-Optical Characteristics'. ESD protection for GaP and AlGaAs based chips is still necessary even though they are safe in low static-electric discharge. Parts built with AlInGaP, GaN, or/and InGaN based chips are **STATIC SENSITIVE devices**. ESD protection has to considered and taken in the initial design stage.

If manual work/process is needed, please ensure the device is well protected from ESD during all the process.

Official Product	HT Part No. HT-193BP5	Your Part No.		Data Sheet No.
Tentative Product	*****	*****		HDS-193-K425
Specifications are subject to changes for improvement without advance notice. Proprietary data, drawings, and company confidential all rights reserved.		2006/12/5	Version of 2.0	Page 4/13

■ **Iv Bin:**

Color	Bin Code	Spec. Range
White	P	45-72mcd
	Q	72-112.5mcd
	R	112.5-180mcd

■ **Color Bin:**

Color	Bin Code	Spec. Range
White	C1	X:0.25-0.27 Y:0.205-0.2775
	C2	X-0.27~0.29 Y-0.233~0.305
	D1	X0.29-0.31 Y:0.26-0.3325
	D2	X:0.31-0.33 Y:0.2875-0.36

■ **Vf Bin:**

Color	Bin Code	Spec. Range
White	G2T	2.55-2.65V
	G3T	2.65-2.75V
	G4T	2.75-2.85V
	H1T	2.85-2.95V
	H2T	2.95-3.05V
	H3T	3.05-3.15V

Official Product	HT Part No. HT-193BP5	Your Part No.		Data Sheet No.
Tentative Product	*****	*****		HDS-193-K425
Specifications are subject to changes for improvement without advance notice. Proprietary data, drawings, and company confidential all rights reserved.		2006/12/5	Version of 2.0	Page 6/13

Product Feature

Electro-Optical Characteristics

(I_F @ 5mA, T_a 25°C)

Code for parts	Lighting Color	Material	V _F (V)		λ (nm)			I _V (mcd)
			typ	max	λ _D	λ _P	Δλ	Min
HT-193BP5	White	InGaN	2.8	3.15	-	X:0.29 Y:0.31	-	45

Package Outline Dimension and Recommended Soldering Pattern for Reflow Soldering

Unit: mm Tolerance: +/-0.1

Outline Dim.	Soldering Pattern
Soldering terminal may shift in x, y direction.	

Absolute Maximum Ratings

(T_a 25°C)

Series	P _d (mW)	I _F (mA)	I _{FP} (mA)	V _R (V)	I _R (uA)	T _{OP} (°C)	T _{ST} (°C)
HT-193 InGaN	74	20	80**	5	<100@ V _R = 5	-30~+80	-40~+85

** Condition for I_{FP} is pulse of 1/10 duty and 0.1msec width

Official Product	HT Part No. HT-193BP5	Your Part No.		Data Sheet No.	
Tentative Product	*****	*****		HDS-193-K425	
Specifications are subject to changes for improvement without advance notice. Proprietary data, drawings, and company confidential all rights reserved.		2006/12/5	Version of 2.0	Page 7/13	

Characteristics of HT-193 Series

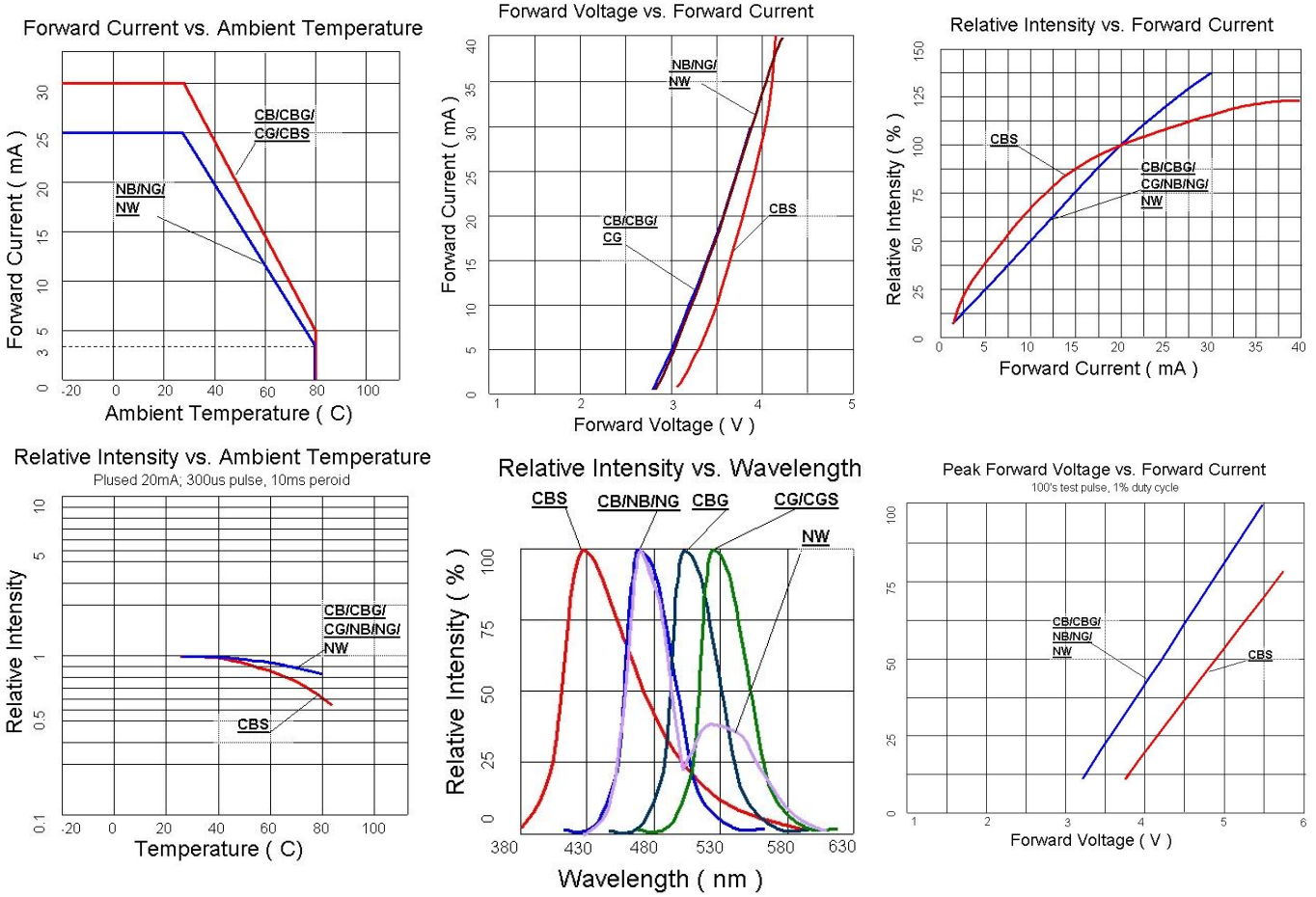

Directive Characteristics

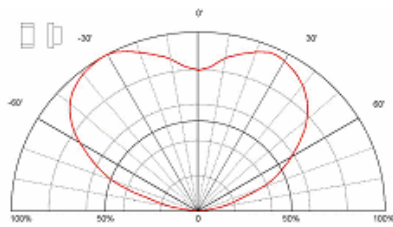

Directive Characteristics

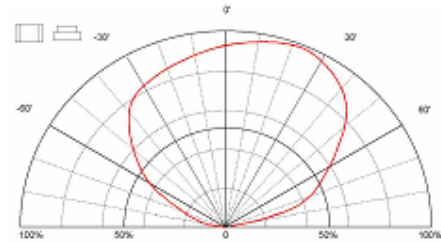

Official Product	HT Part No. HT-193BP5	Your Part No.	Data Sheet No.
Tentative Product	*****	*****	HDS-193-K425
Specifications are subject to changes for improvement without advance notice. Proprietary data, drawings, and company confidential all rights reserved.		2006/12/5	Version of 2.0
			Page 8/13

Packaging Tape, Reel, and Packing Model Tape Dimension

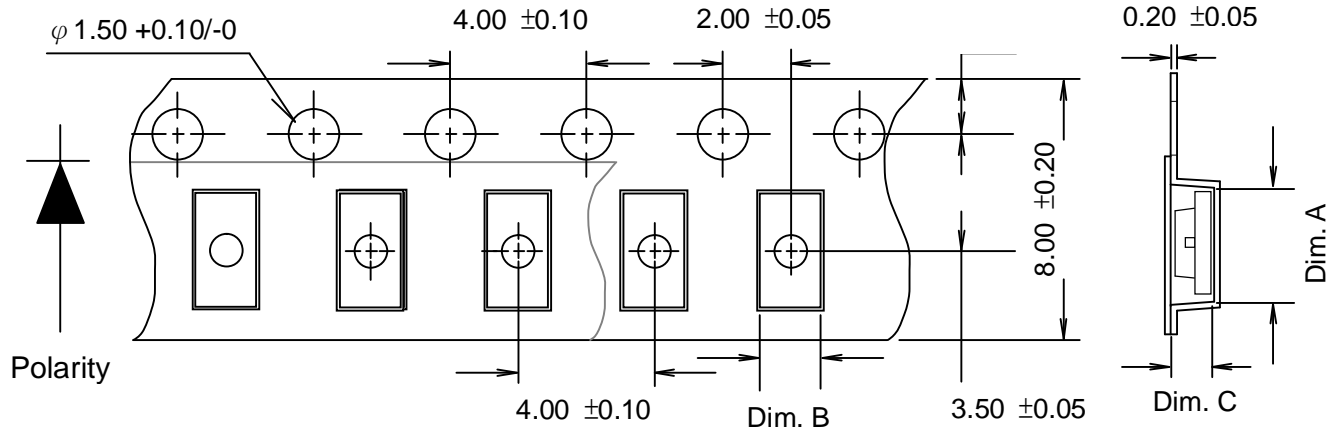

Part No.	Dim. A	Dim. B	Dim. C	Q'ty/Reel
HT-193	1.75±0.1	0.9±0.1	0.60±0.1	4K

Reel Dimension

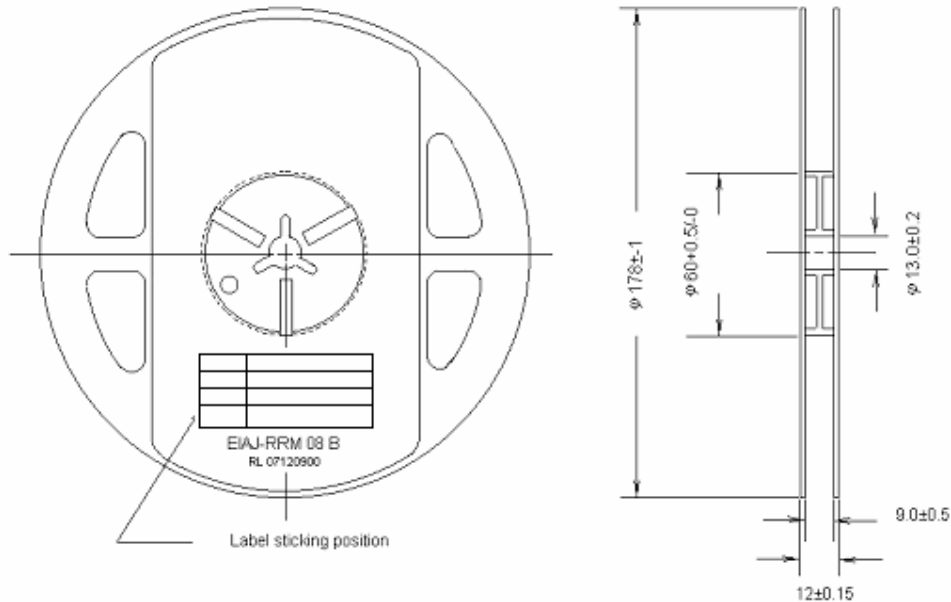

Official Product	HT Part No. HT-193BP5	Your Part No.		Data Sheet No.
Tentative Product	*****	*****		HDS-193-K425
Specifications are subject to changes for improvement without advance notice. Proprietary data, drawings, and company confidential all rights reserved.		2006/12/5	Version of 2.0	Page 9/13

Packing Model

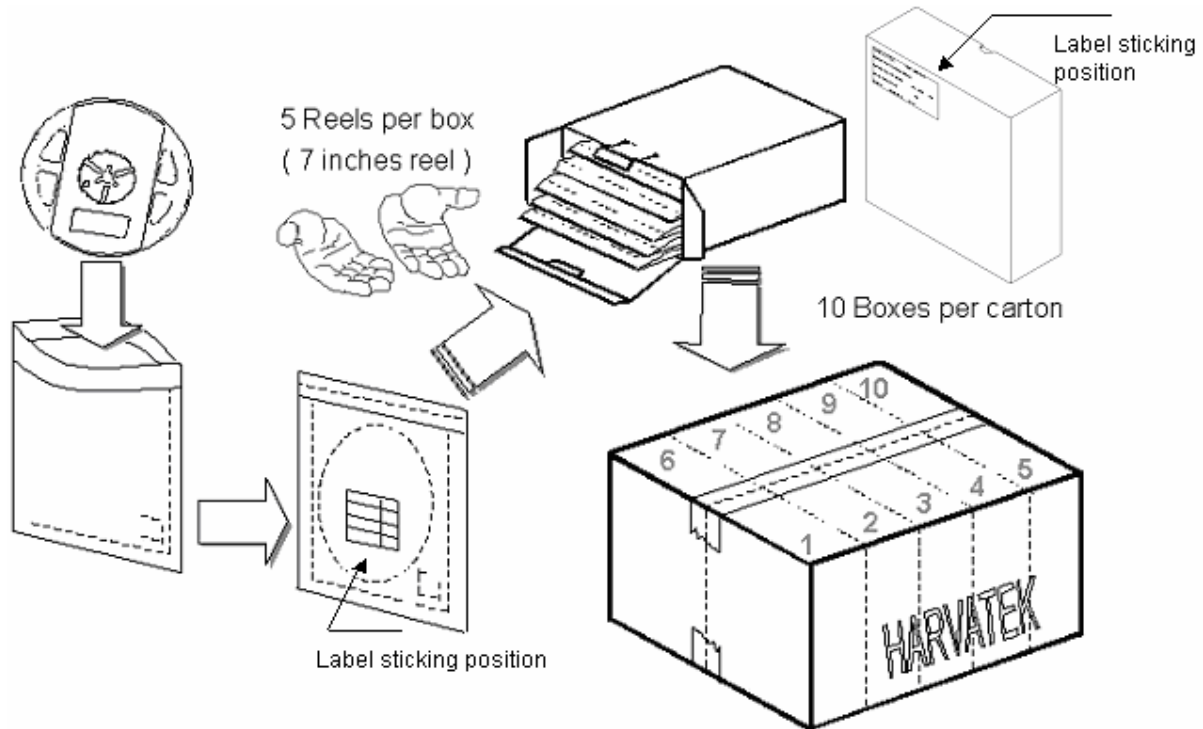

5 boxes per carton is available according to shipping quantity.

Dry Pack

Any SMD optical device, like this chip LED, is **MOISTURE SENSITIVE device**. Avoid absorbing moisture at any time during transportation or storage. Every reel will be packaged in the moisture barrier anti-static bag (Specific bag material will depend upon customers' requirement or option). And the bag is well sealed before shipment.

By customer's requirement, we will put a humidity indicator in each moisture barrier anti-static bag before shipment.

The package is the following:

Official Product	HT Part No. HT-193BP5	Your Part No.	Data Sheet No.
Tentative Product	*****	*****	HDS-193-K425
Specifications are subject to changes for improvement without advance notice. Proprietary data, drawings, and company confidential all rights reserved.		2006/12/5	Version of 2.0 Page 10/13

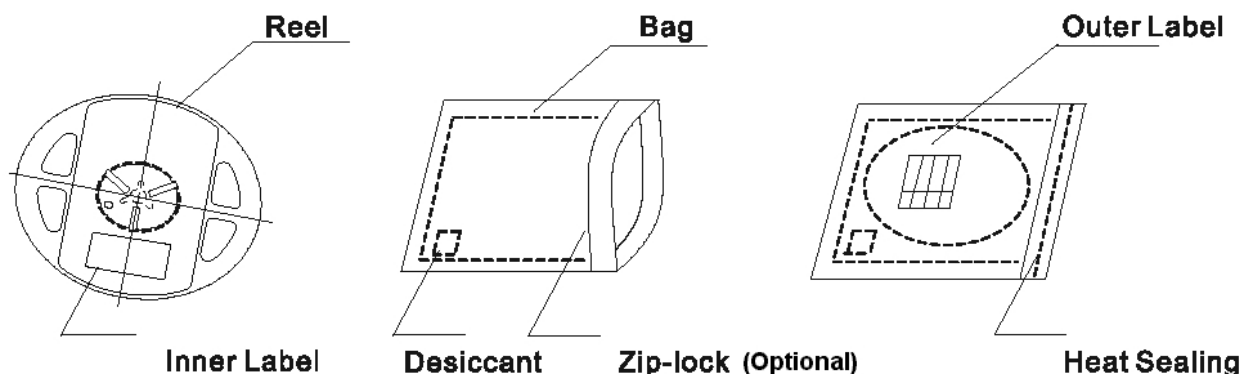

Cautions of Pick and Place

It should be avoided to load stress on the resin during high temperature.

Avoid rubbing or scraping the resin by any object.

Electric-static may cause damage to the component. Please confirm that the equipment grounding well. Using an ionizer fan is recommended.

PRECAUTIONS

1. Avoid absorbing moisture at any time during transportation or storage.
2. Anti-Static process is needed especially when handling GaN, InGaN, and AlInGaP products.
3. It is suggested to connect the unit with a proper series current limit resistor. Avoid driving reverse voltage over the specification of LEDs when turning the unit ON/OFF.
4. Any application should refer to the specifications of absolute maximum ratings.
5. Avoid any direct contact with the viewing area.
6. If possible, assemble the unit in a clean room or dust-free environment.

Reflow Soldering

- ◆ Recommend tin glue specifications:
Melting temperature: 178~192 °C
- ◆ Never take next process until the component is cooled down to room temperature after reflow.
- ◆ The recommended reflow soldering profile (measuring on the surface of the LED resin) is following:

Official Product	HT Part No. HT-193BP5	Your Part No.	Data Sheet No.
Tentative Product	*****	*****	HDS-193-K425
Specifications are subject to changes for improvement without advance notice. Proprietary data, drawings, and company confidential all rights reserved.		2006/12/5	Version of 2.0 Page 11/13

Lead Solder

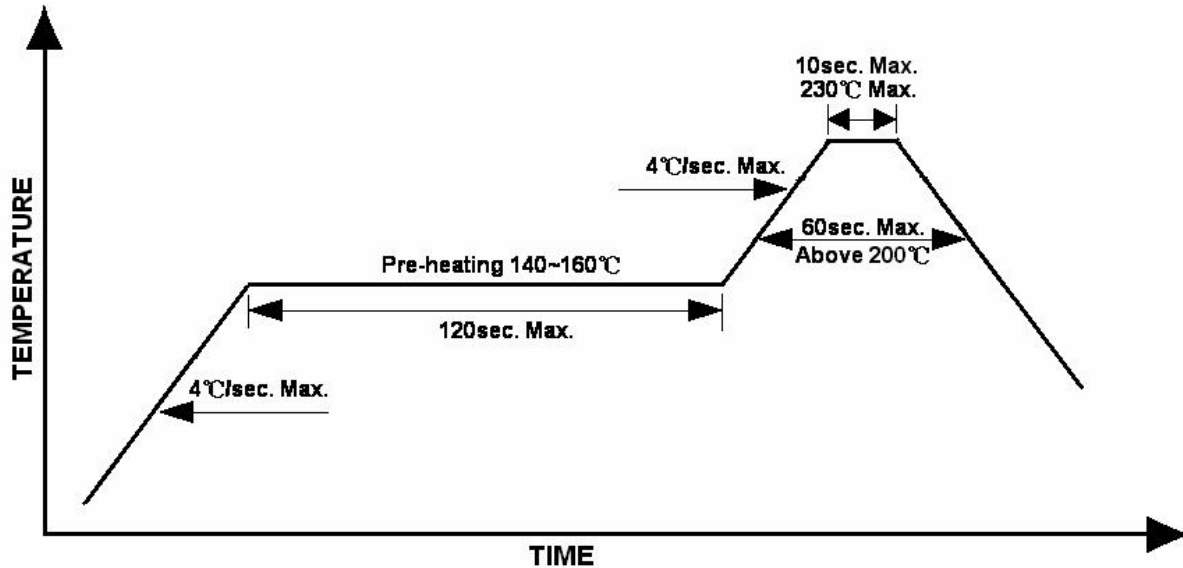

Lead-free Solder

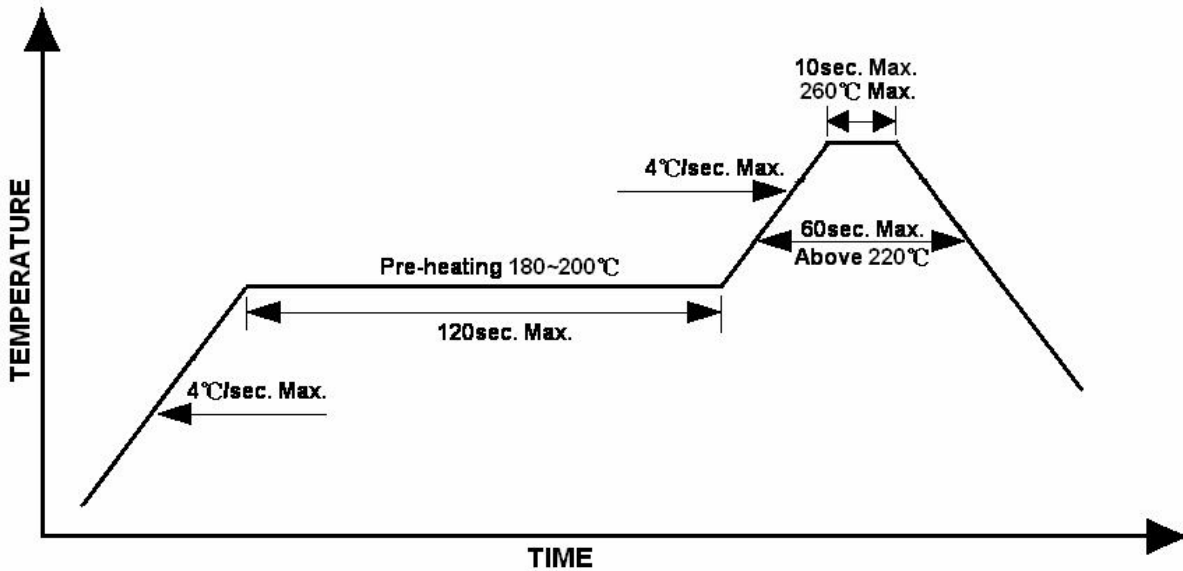

Rework

- ◆ Customer must finish rework within 5 sec. under 260 °C.
- ◆ The head of iron cannot touch copper foil.
- ◆ Twin-head type is preferred.

Official Product	HT Part No. HT-193BP5	Your Part No.		Data Sheet No.
Tentative Product	*****	*****		HDS-193-K425
Specifications are subject to changes for improvement without advance notice. Proprietary data, drawings, and company confidential all rights reserved.		2006/12/5	Version of 2.0	Page 12/13

Reliability Test

Item	Frequency/ lots/ samples/ failures	Standards Reference	Conditions
Precondition	For all reliability monitoring tests according to JEDEC Level 2	J-STD-020	1.) Baking at 85°C for 24hrs 2.) Moisture storage at 85°C/ 60% R.H. for 168hrs
Solderability	1Q/ 1/ 22/ 0	JESD22-B102-B And CNS-5068	Accelerated aging 155°C/ 24hrs Tinning speed: 2.5±0.5cm/s Tinning: A: 215°C/ 3±1s or B: 260°C/ 10±1s
Resistance to soldering heat		CNS-5067	Dipping soldering terminal only Soldering bath temperature A: 260+/-5°C; 10+/-1s B: 350+/-10°C; 3+/-0.5s
Operating life test	1Q/ 1/ 40/ 0	CNS-11829	1.) Precondition: 85°C baking for 24hrs 85°C/ 60%R.H. for 168hrs 2.) T _{amb} 25°C; I _F =20mA; duration 1000hrs
High humidity, high temperature bias	1Q/ 1/ 45/ 0	JESD-A101-B	T _{amb} : 85°C Humidity: 85% R.H., I _F =5mA Duration: 1000hrs
High temperature bias	1Q/ 1/ 20/ 0	HT specs.	T _{amb} : 55°C I _F =20mA Duration: 1000hrs
Pulse life test	1Q/ 1/ 40/ 0		T _{amb} 25°C, I _F =20mA, I _p =100mA, Duty cycle=0.125 (tp=125 μs, T=1sec) Duration 500hrs)
Temperature cycle	1Q/ 1/ 76/ 0	JESD-A104-A IEC 68-2-14, Nb	A cycle: -40 degree C 15min; +85 degree C 15min Thermal steady within 5 min.. 300 cycles 2 chamber/ Air-to-air type
High humidity storage test	1Q/ 1/ 40/ 0	CNS-6117	60±3°C 90+5/-10% R.H. for 500hrs
High temperature storage test	1Q/ 1/ 40/ 0	CNS-554	100±10°C for 500hrs
Low temperature storage test	1Q/ 1/ 40/ 0	CNS-6118	-40±5°C for 500hrs

Official Product	HT Part No. HT-193BP5	Your Part No.		Data Sheet No.
Tentative Product	*****	*****		HDS-193-K425
Specifications are subject to changes for improvement without advance notice. Proprietary data, drawings, and company confidential all rights reserved.		2006/12/5	Version of 2.0	Page 13/13